



Model: 116311-01

DESCRIPTION

- Two stage
- 120 volts
- 5.7"/145 mm diameter
- Double ball bearings
- Single speed
- Thru-flow discharge
- Aluminum fan end bracket
- Aluminum commutator bracket

DESIGN APPLICATION

- Equipment operating in environments not requiring separation of working air from motor ventilating air
- Designed to handle clean, dry, filtered air only

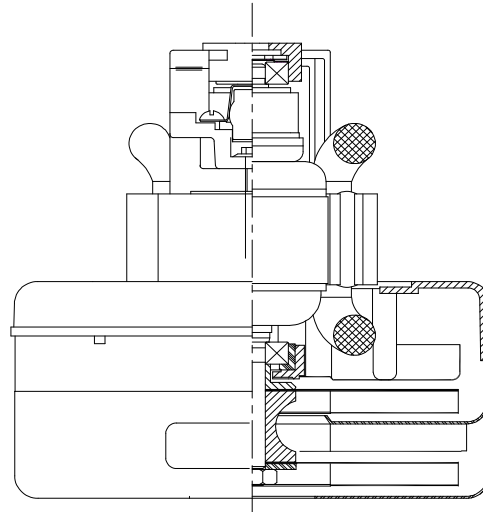

SPECIAL FEATURES

- Suitable for 120 volt AC operation, 50/60 Hz
- UL recognized, category PRGY2 (E47185)
- CSA Certified, class 1611 01 (LR31393)
- Provision for grounding
- Skeleton-frame design
- The Lamb Electric vacuum motor line offers a wide range of performance levels to meet design needs

TYPICAL MOTOR PERFORMANCE.*

(At 120 volts, 60Hz, test data is corrected to standard conditions of 29.92 Hg, 68° F.)

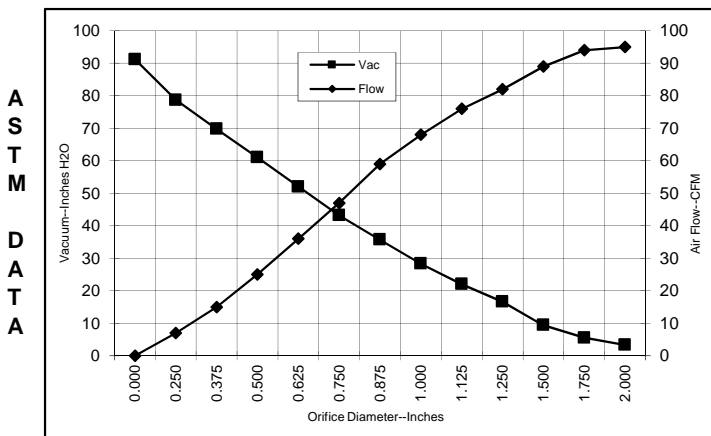

Orifice (Inches)	Amps	Watts (In)	RPM	Vac (In.H ₂ O)	Flow (CFM)	Air Watts
2.000	8.1	909	17840	3.3	95.0	36
1.750	8.1	914	17800	5.5	94.0	60
1.500	8.2	922	17740	9.4	89.0	97
1.250	8.3	928	17660	16.6	82.0	160
1.125	8.2	927	17670	22.0	76.0	198
1.000	8.2	917	17720	28.3	68.0	226
0.875	8.0	896	17990	35.7	59.0	245
0.750	7.6	862	18390	43.2	47.0	239
0.625	7.1	809	19050	52.0	36.0	218
0.500	6.6	747	19910	61.0	25.0	176
0.375	5.9	678	20990	69.8	15.0	123
0.250	5.3	615	22140	78.7	7.0	68
0.000	4.9	564	23240	91.2	0.0	0

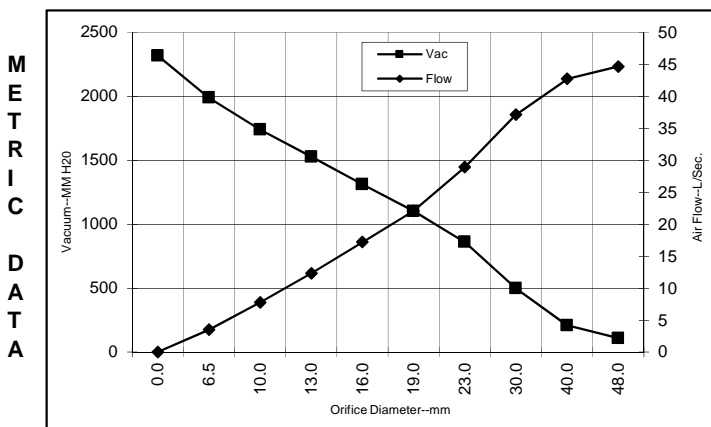

Orifice (mm)	Amps	Watts (In)	RPM	Vac (mm H ₂ O)	Flow (L/Sec)	Air Watts
48.0	8.1	911	17822	108	44.6	47
40.0	8.2	920	17758	209	42.7	86
30.0	8.2	927	17666	497	37.1	181
23.0	8.1	901	17923	860	28.9	240
19.0	7.6	861	18403	1102	22.1	239
16.0	7.1	811	19024	1312	17.2	219
13.0	6.7	753	19824	1527	12.3	180
10.0	6.0	688	20828	1739	7.8	131
6.5	5.3	618	22083	1988	3.5	71
0.0	4.9	564	23240	2316	0.0	0

Note: Metric performance data is calculated from the ASTM data above.

* Data represents performance of a typical motor sampled from a large production quantity. Individual motor data may vary due to normal manufacturing variations.

Test Specs:	120 volts	Minimum Sealed Vacuum:	85.0"	ORIFICE:	7/8 "	Minimum Vacuum:	32.0"	Maximum Watts:	950
--------------------	-----------	-------------------------------	-------	-----------------	-------	------------------------	-------	-----------------------	-----

DIMENSIONS

NOTES:

1. LEADS: 18GA STRANDED, LEADS CAN BE ANY COLOR EXCEPT GREEN OR GREEN WITH YELLOW STRIPE.
2. GROUNDING OR EARTHING PROVISIONS: USE HOLES AS INDICATED FOR GROUNDING OR EARTHING. REFER TO APPROPRIATE LISTING OR REGULATORY AGENCY FOR PROPER METHOD OF GROUNDING OR EARTHING.
3. MOTOR IDENTIFICATION: MANUFACTURER'S NAME, MODEL NUMBER, VOLTAGE, FREQUENCY, INSPECTOR'S CODE, DATE OF MANUFACTURE, AGENCY RECOGNITION CODE, PLANT LOCATION CODE AND COUNTRY OF ORIGIN.
4. MOUNTING MUST NOT RESTRICT THIS DIAMETER.
5. TO INSURE NORMAL OPERATING LIFE TIME, THIS MOTOR MUST BE OPERATED AT 400HZ IN CONJUNCTION WITH A FULL WAVE BRIDGE (RECTIFIER).

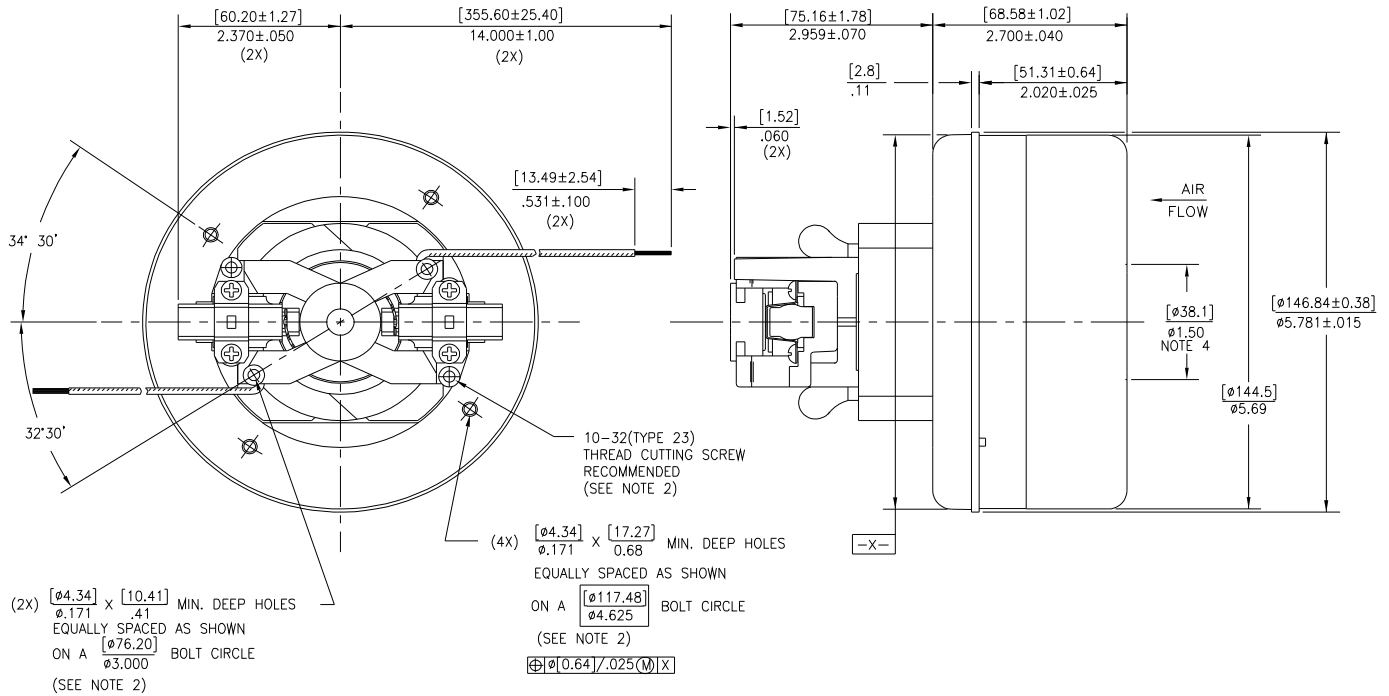

IMPORTANT NOTE: Pictorial and dimensional data are subject to change without notice. Contact factory for current revision levels.

WARNING - AMETEK Lamb Electric thru-flow vacuum motors must never be used in applications in which wet or moist conditions are involved, where dry chemicals or other volatile materials are present, or where airflow may be restricted or blocked. Such motors are designed to permit the vacuumed air to pass over the electrical winding to cool it. Thus any foam, liquid (including water), dry chemical, or other foreign substance coming in contact with electrical conductors could cause combustion (depending on volatility) or electrical shock. Failure to observe these precautions could result in property damage and severe personal injury, including death in extreme cases. All applications incorporating Lamb Electric motors should be submitted to Underwriters Laboratories Inc. or other appropriate organizations or agencies for testing specifically related to the safety of your equipment.

AMETEK/Floorcare & Specialty Motors
www.ametekfsm.com