



**AMETEK**  
**LAMB ELECTRIC**

**Product Bulletin**

**Model: 116259-00**

**DESCRIPTION**

- Two stage
- 240 volts
- 5.7"/145 mm diameter
- Double ball bearings
- Single speed
- Tangential bypass discharge
- Thermoset fan end bracket
- Aluminum commutator bracket

**DESIGN APPLICATION**

- Equipment operating in environments requiring separation of working air from motor ventilating air
- Designed to handle clean, dry, filtered air only

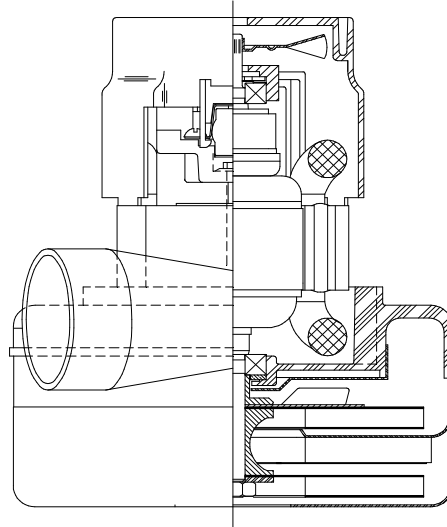

**SPECIAL FEATURES**

- Suitable for 240 volt AC operation, 50/60 Hz
- UL recognized, category PRGY2 (E47185)
- Provision for grounding
- Skeleton-frame design
- The Lamb Electric vacuum motor line offers a wide range of performance levels to meet design needs
- Patented air seal bearing protection, U.S. Patent #4,088,424 and epoxy painted fan case
- 116259-11 has an interrupter brush

**TYPICAL MOTOR PERFORMANCE.\***

(At 240 volts, 60Hz, test data is corrected to standard conditions of 29.92 Hg, 68° F.)

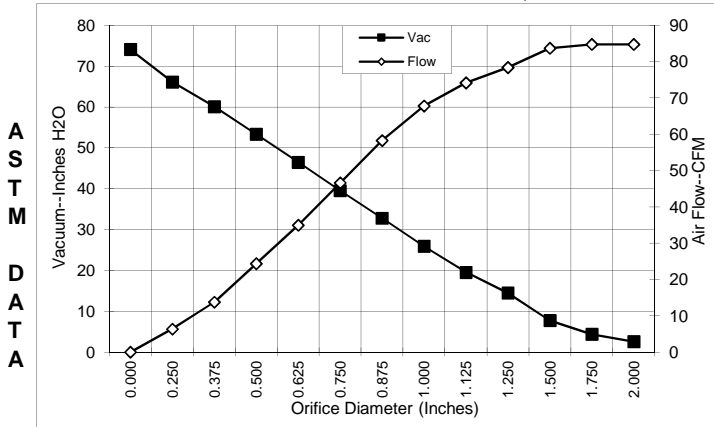

Orifice (Inches)	Amps	Watts (In)	RPM	Vac (In.H <sub>2</sub> O)	Flow (CFM)	Air Watts
2.000	3.6	799	18121	2.6	84.8	25
1.750	3.6	803	18015	4.4	84.8	44
1.500	3.6	809	17909	7.7	83.7	76
1.250	3.7	826	17724	14.5	78.4	134
1.125	3.7	828	17671	19.5	74.2	171
1.000	3.7	828	17671	25.9	67.8	207
0.875	3.7	821	17883	32.8	58.3	225
0.750	3.5	787	18280	39.5	46.6	218
0.625	3.5	756	18837	46.5	35.0	193
0.500	3.2	707	19684	53.3	24.4	152
0.375	2.9	663	20585	60.1	13.8	102
0.250	2.7	616	21618	66.1	6.4	52
0.000	2.5	582	22307	74.1	0.0	0

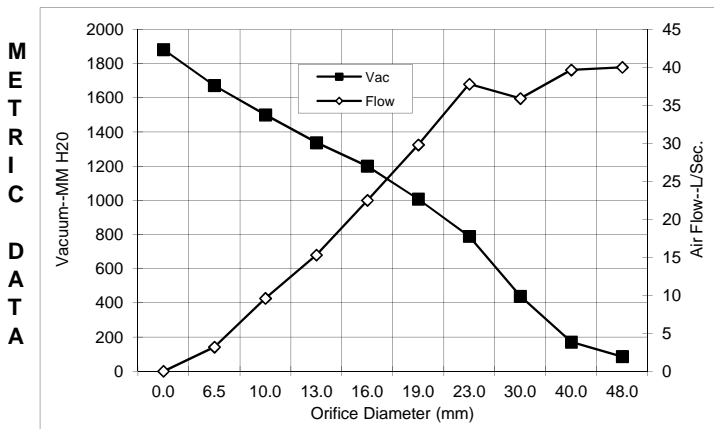

Orifice (mm)	Amps	Watts (In)	RPM	Vac (mm H <sub>2</sub> O)	Flow (L/Sec)	Air Watts
48.0	3.6	801	18075	86	40.0	33
40.0	3.6	807	17941	171	39.7	67
30.0	3.7	827	17695	439	35.9	155
23.0	3.7	823	17830	789	37.8	515
19.0	3.5	786	18291	1008	29.8	528
16.0	3.5	757	18814	1200	22.5	470
13.0	3.2	712	19600	1338	15.3	156
10.0	3.0	669	20450	1500	9.6	110
6.5	2.7	619	21567	1672	3.2	55
0.0	2.5	582	22307	1883	0.0	0

Note: Metric performance data is calculated from the ASTM data above.

\* Data represents performance of a typical motor sampled from a large production quantity. Individual motor data may vary to normal manufacturing variations.

<b>Test Specs:</b>	<b>240 volt</b>	<b>Minimum Sealed Vacuum: 74"</b>	<b>ORIFICE: 7/8"</b>	<b>Minimum Vacuum: 31"</b>	<b>Maximum Watts: 975</b>
--------------------	-----------------	-----------------------------------	----------------------	----------------------------	---------------------------

**DIMENSIONS**

NOTES:

1. LEADS: 18GA STRANDED, LEADS CAN BE ANY COLOR EXCEPT GREEN OR GREEN WITH YELLOW STRIPE.
2. GROUNDING OR EARTHING PROVISIONS: USE HOLES AS INDICATED FOR GROUNDING OR EARTHING. REFER TO APPROPRIATE LISTING OR REGULATORY AGENCY FOR PROPER METHOD OF GROUNDING OR EARTHING.

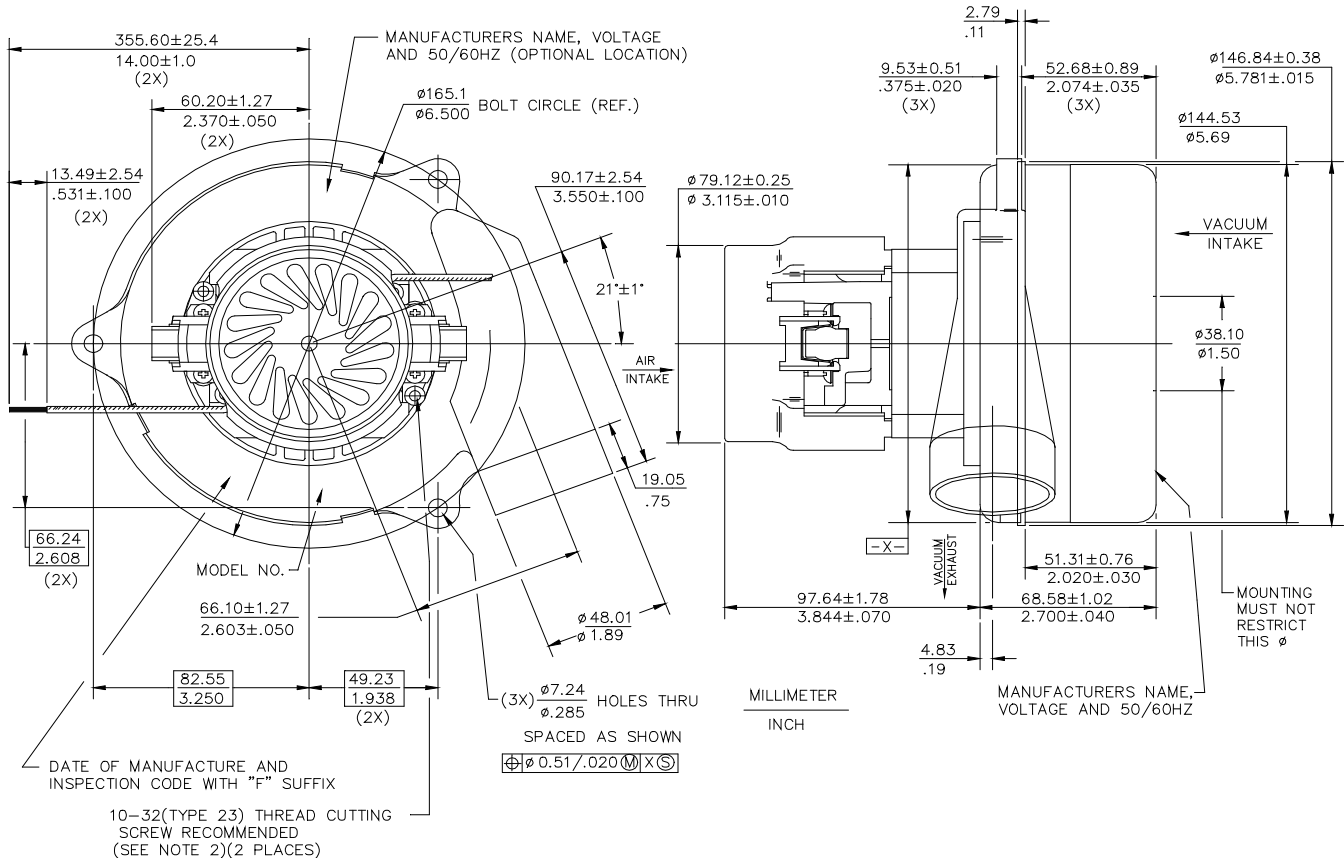

**IMPORTANT NOTE:** Pictorial and dimensional data are subject to change without notice. Contact factory for current revision levels.

**WARNING** - When using AMETEK/Lamb Electric bypass motors in machines that come in contact with foam, liquid (including water) of other foreign substances, the machine must be designed and constructed to prevent those substances from reaching the fan system, motor housing and electrical components. Lamb vacuum motors other than hazardous duty models should not be applied in machines that come in contact with dry chemicals or other volatile materials. Failure to observe these precautions could cause flashing (depending on volatility) or electrical shock which could result in property damage and severe bodily injury, including death in extreme cases. All applications incorporating Lamb motors should be submitted to appropriate organizations or agencies for testing specifically related to the safety of your equipment.

**AMETEK/Floorcare & Specialty Motors**  
[www.ametekfsm.com](http://www.ametekfsm.com)