



# AMETEK LAMB ELECTRIC

## Product Bulletin

Model: 115950

### DESCRIPTION

- Two stage
- 240 volts
- 7.2"/183 mm diameter
- Double ball bearings
- Single speed
- Tangential bypass discharge
- Aluminum fan end bracket
- Aluminum commutator bracket

### DESIGN APPLICATION

- Equipment operating in environments requiring separation of working air from motor ventilating air
- Designed to handle clean, dry, filtered air only

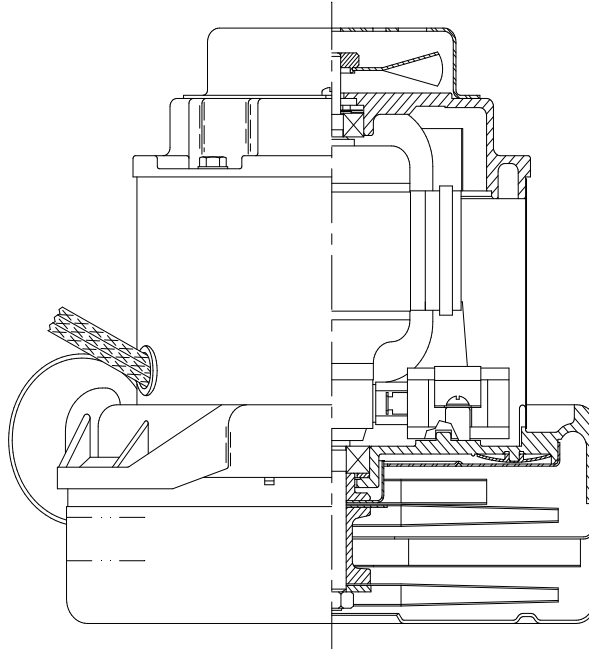

### SPECIAL FEATURES

- Suitable for 240 volt AC operation, 50/60 Hz
- UL recognized, category PRGY2 (E47185)
- Provision for grounding
- Epoxy painted fan case
- Patented air seal bearing construction, U.S. Patent #4,088,424
- The Lamb Electric vacuum motor line offers a wide range of performance levels to meet design needs

### TYPICAL MOTOR PERFORMANCE.\*

(At 240 volts, 60Hz, test data is corrected to standard conditions of 29.92 Hg, 68° F.)

ASTM DATA

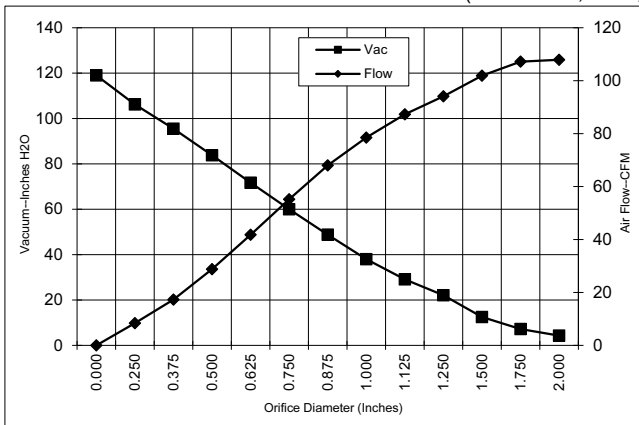

Orifice (Inches)	Amps	Watts (In)	RPM	Vac (In.H <sub>2</sub> O)	Flow (CFM)	Air Watts
2.000	7.5	1593	16550	4.3	107.9	54
1.750	7.5	1593	16453	7.2	107.2	92
1.500	7.5	1593	16386	12.5	101.9	150
1.250	7.5	1596	16393	22.1	94.1	245
1.125	7.5	1589	16450	29.1	87.3	299
1.000	7.4	1570	16574	38.0	78.5	350
0.875	7.3	1544	16758	48.8	68.0	390
0.750	7.0	1494	17130	60.0	55.2	389
0.625	6.7	1435	17736	71.7	41.8	352
0.500	6.2	1322	18565	83.8	28.8	284
0.375	5.6	1212	19634	95.5	17.3	194
0.250	5.1	1115	20675	106.2	8.4	105
0.000	4.9	1073	21623	119.0	0.0	0

METRIC DATA

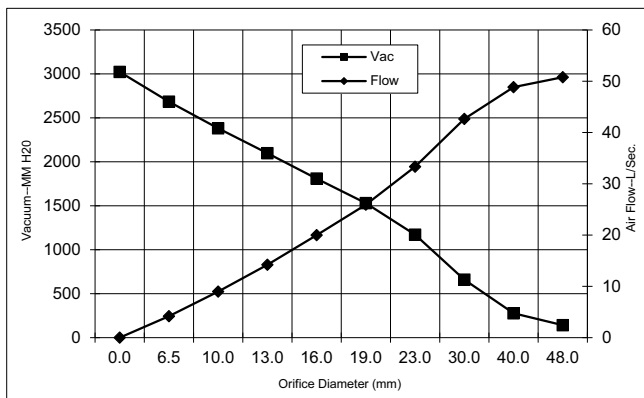

Orifice (mm)	Amps	Watts (In)	RPM	Vac (mm H <sub>2</sub> O)	Flow (L/Sec)	Air Watts
48.0	7.5	1593	16507	142	50.8	71
40.0	7.5	1593	16406	277	48.8	133
30.0	7.5	1592	16424	659	42.6	275
23.0	7.3	1551	16712	1171	33.3	380
19.0	7.0	1493	17142	1530	25.9	388
16.0	6.7	1437	17712	1809	20.0	353
13.0	6.3	1333	18482	2098	14.2	291
10.0	5.7	1229	19474	2381	9.0	208
6.5	5.1	1120	20623	2684	4.2	109
0.0	4.9	1073	21623	3023	0.0	0

Note: Metric performance data is calculated from the ASTM data above.

\* Data represents performance of a typical motor sampled from a large production quantity. Individual motor data may vary due to normal manufacturing variations.

Test Specs: 220 volts Minimum Sealed Vacuum: 99" ORIFICE: 7/8" Minimum Vacuum: 40" Maximum Watts: 1600

**DIMENSIONS**

NOTES:

1. LEADS: POWER: #16 GA., ONE BLACK, ONE WHITE.  
GROUND: #18 GA., GREEN WITH YELLOW STRIPE.

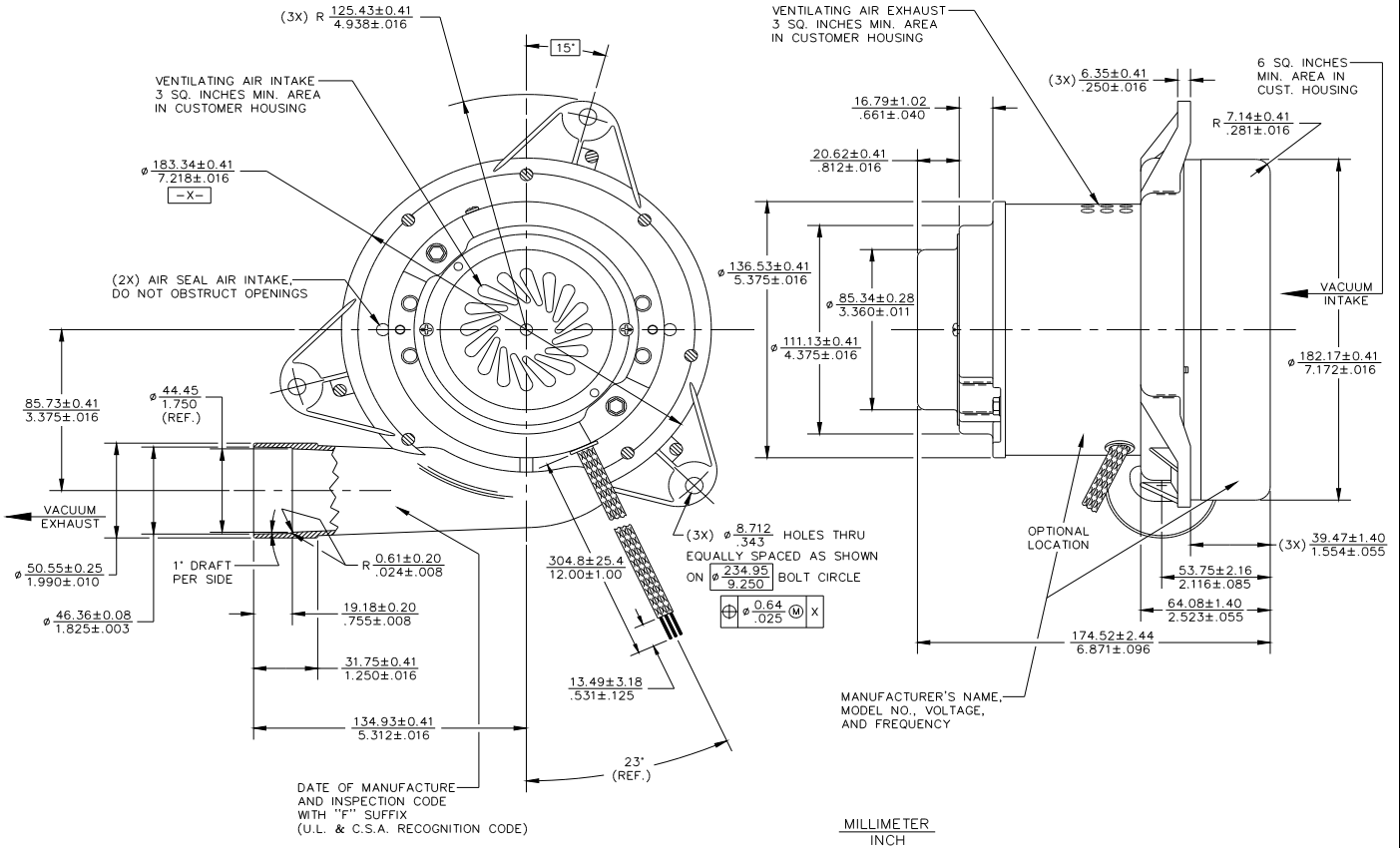

**IMPORTANT NOTE:** Pictorial and dimensional data are subject to change without notice. Contact factory for current revision levels.

**WARNING** - When using AMETEK Lamb Electric bypass motors in machines that come in contact with foam, liquid (including water), or other foreign substances, the machine must be designed and constructed to prevent those substances from reaching the fan system, motor housing, and electrical components. Lamb Electric vacuum motors other than hazardous duty models should not be applied in machines that come in contact with dry chemicals or other volatile materials. Failure to observe these precautions could cause flashing (depending on volatility) or electrical shock which could result in property damage and severe bodily injury, including death in extreme cases. All applications incorporating Lamb Electric motors should be submitted to appropriate organizations or agencies for testing specifically related to the safety of your equipment.

**AMETEK Dynamic Fluid Solutions**  
**www.ametekdfs.com**